

NJ Series Collector Specifications

NJ-1800-XX Collector Dimensions

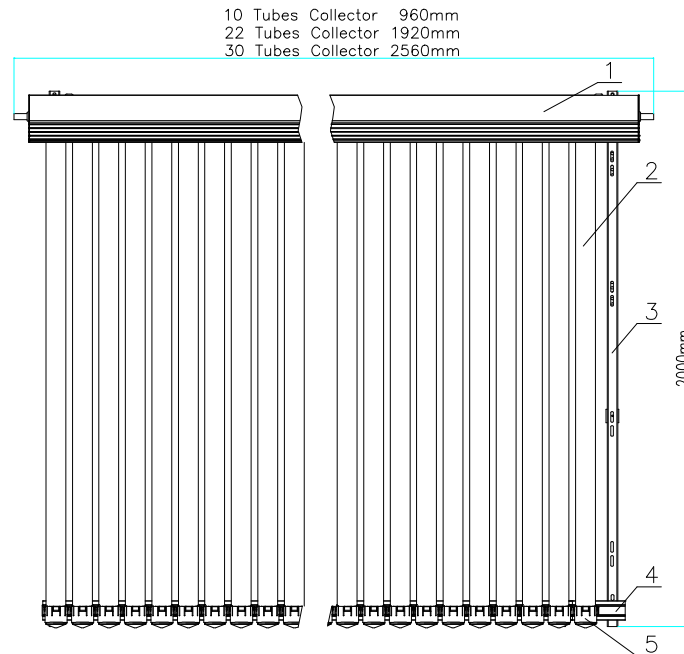

- | | | |
|----------------|-------------------|-----------------|
| 1. Header | 2. NJ58-1800 tube | 3. Side channel |
| 4. Bottom rail | 5. Tube holder | |

NJ Collector Specifications

Model No.	NJ-1800-10	NJ-1800-22	NJ-1800-30
Tube structure	NJ58-1800	NJ58-1800	NJ58-1800
Number of tubes	10	22	30
Absorber area, m²	0.800	1.761	2.401
ft²	8.615	18.952	25.844
Aperture area, m²	0.933	2.074	2.800
ft²	10.046	22.324	30.139
Gross area, m²	1.76	3.64	4.949
ft²	18.944	39.181	53.271
Overall size, W x L, mm	960x2000	1920x2000	2560x2000
ft	3.150x6.562	6.299x6.562	8.399x6.562
Weight, kg	39	82	102
Lbs	85.980	180.779	224.872
Volume of the fluid, L	0.56	1.26	1.77
Pressure Stand, Bar	6	6	6
PSI	87.023	87.023	87.023
Material of insulation	rock wool	rock wool	rock wool
Material of header casing	Powder coated steel	Powder coated steel	Powder coated steel
Material of Manifold	Copper	Copper	Copper
Material of Frame	Aluminum	Aluminum	Aluminum

NJ Series Collector Specifications

NJ58-1800 Heat Pipe Vacuum Tube

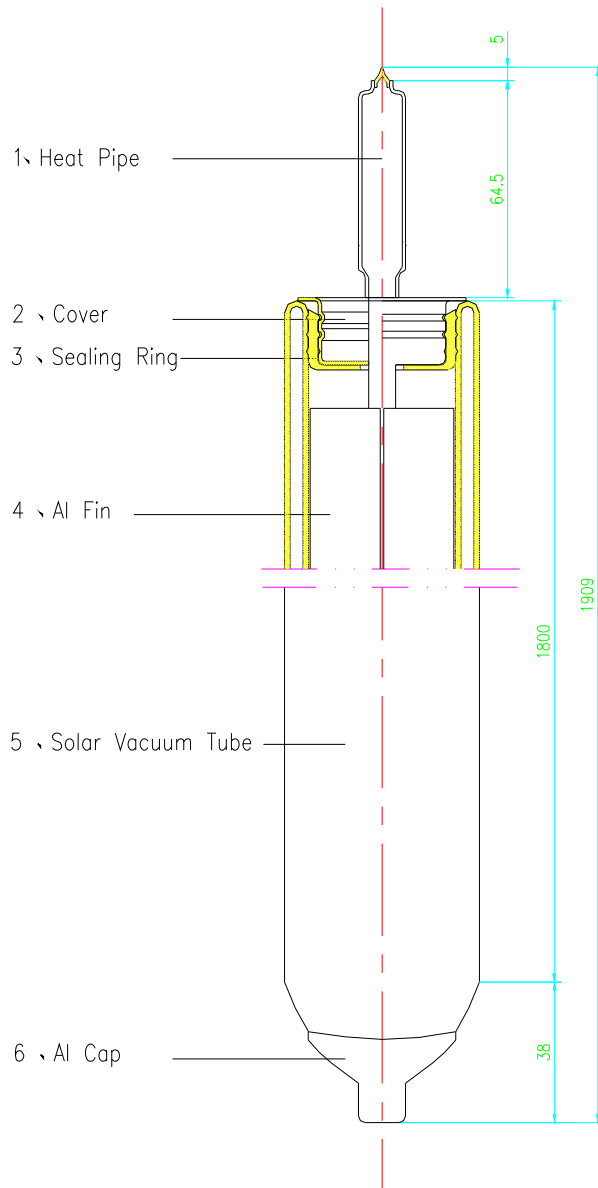

Structure	Normal Heat Pipe Vacuum Tube
Absorption coefficient	≥ 0.93
Emission coefficient	≤ 0.08
Isolation temperature	230 ⁰ C
High vacuum, long-term stability	5×10^{-2} Pa
Freezing tolerance	-40 ⁰ C
Hail resistance	Ø25mm
Wind resistance	30m/s
Diameter of condenser	Ø14×75mm
Glass material	High-quality borosilicate glass
Absorber material	Aluminum
Coating	Aluminum Nitride, black
Single tube weight	2.0kg
Absorber area	0.08 M2 flat /0.12 M2 tubular
Glass tube diameter	58mm outer/47mm inner
Glass tube length	1800mm
Glass wall thickness	1.6mm

NJ Series Collector Specifications

NJ-1800-XX Collector Header

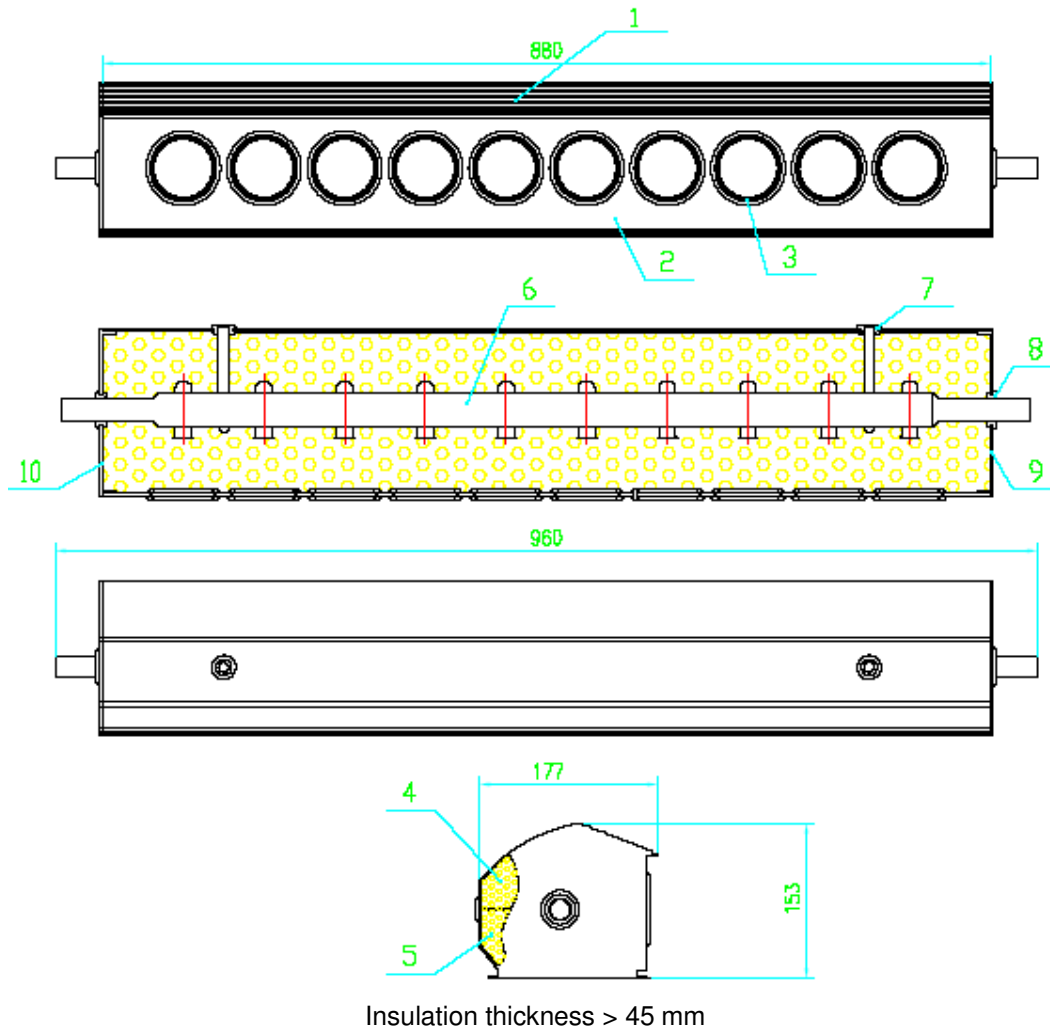

- | | | | |
|-----|----------------------|------|--------------|
| 1&2 | Header casing | 7 | Sensor well |
| 3 | Sealing ring | 8 | Sealing ring |
| 4&5 | Rock wool insulation | 9&10 | Side cover |
| 6 | Manifold | | |

NJ Series Collector Specifications

Collector Frame Assembly

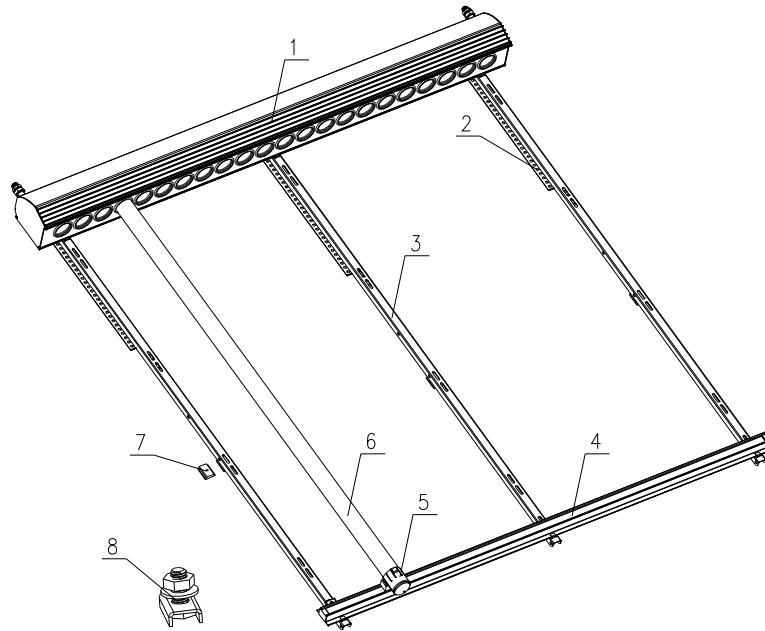

- 1.manifold 2.Roof Strap 3.Front Track 4.Bottom Track
5.Feet Holder 6.Tube 7.Rubber pad 8.Bolt&Nut Lock Assembly

Note: NJ-1800-10 and NJ-1800-22 only have two front Tracks

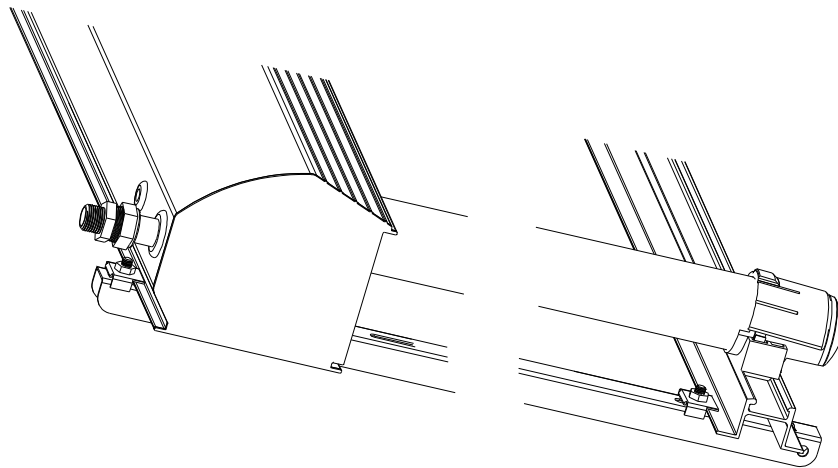

Flush Mounting for High Pitched Roof

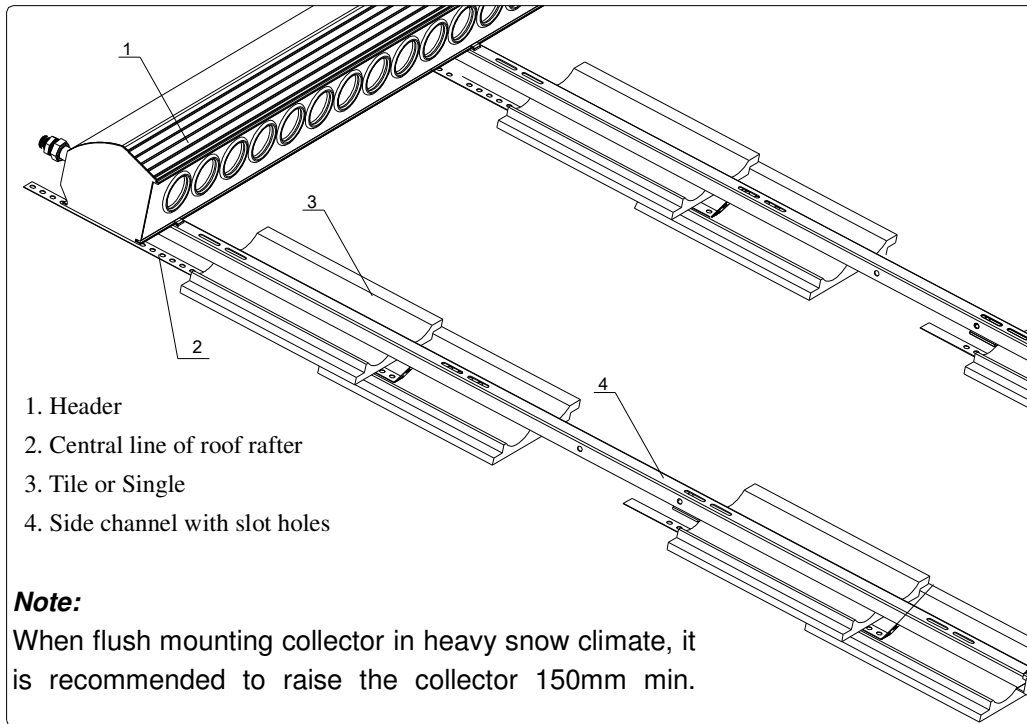

Side channels (4) can slide along the header to locate in the central line of the rafters underneath the tiles or singles.



Slot holes are available on the side channels (4) for using bolts and screws to attach the collector frame to the rafters underneath the tiles or singles

NJ Series Collector Specifications

Racking for Low-pitched Roof

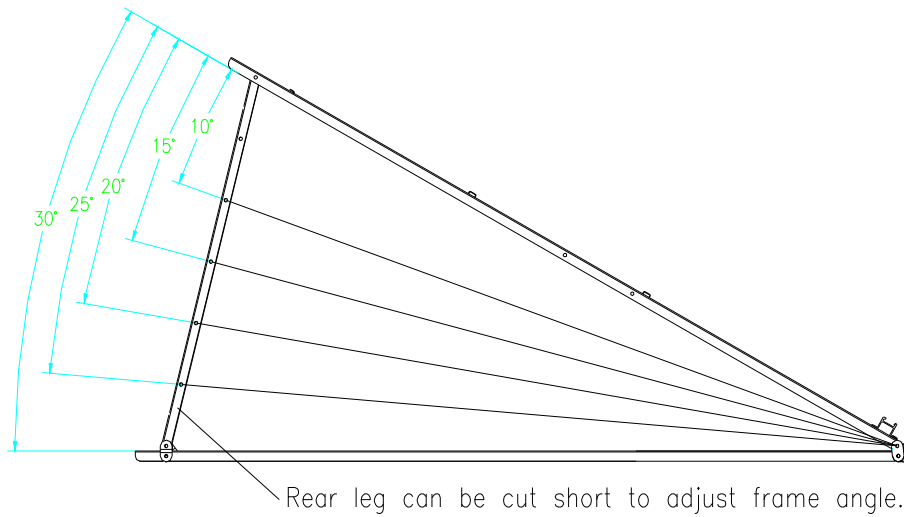
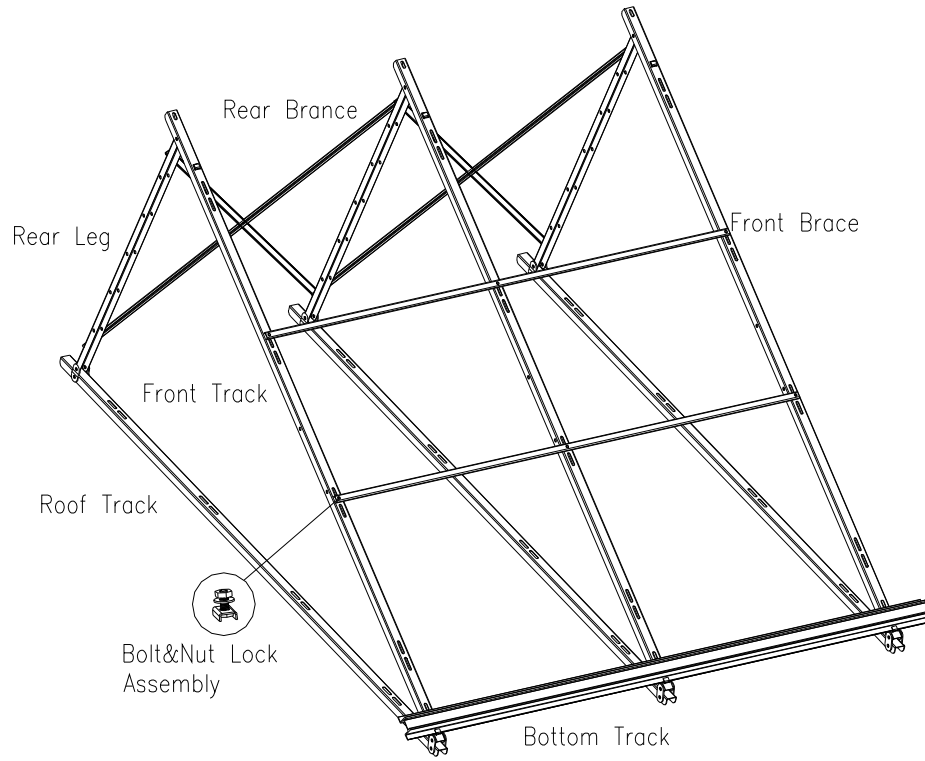

Racking for Flat Roof

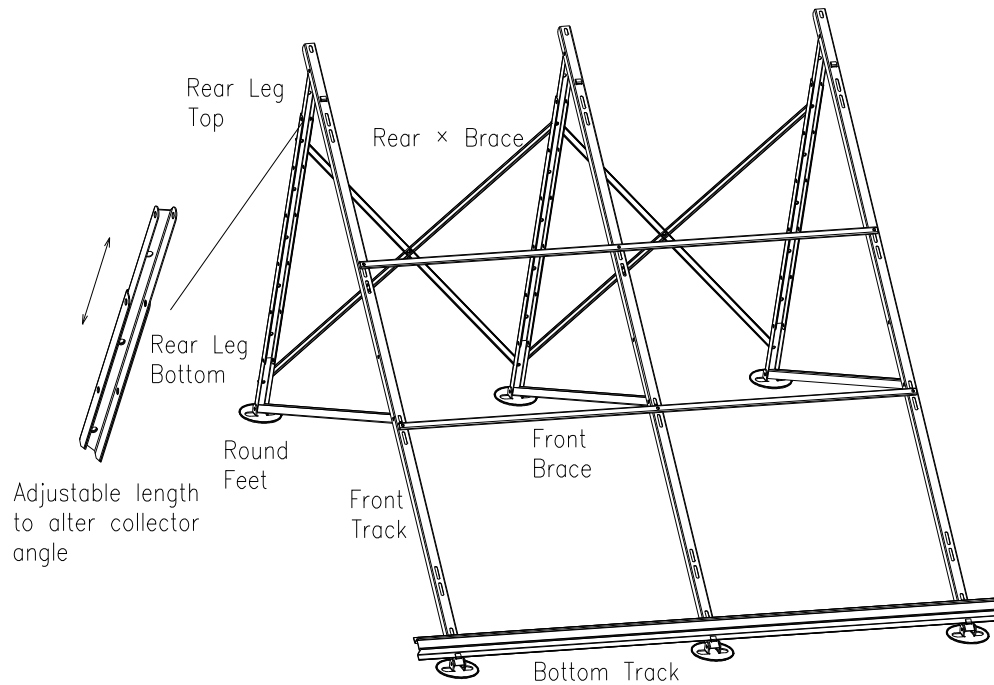

NOTES: Feet must be bolted to roof structure.

NJ-1800-10 & 22 collector frames use:

2 sets of front track, rear legs and diagonal brace

1 set of rear X brace assembly

NJ-1800-30 collector frames use:

3 sets of front track, rear legs and diagonal brace

2 sets of rear X brace assembly